

*TB 9-6625-2057-24

DEPARTMENT OF THE ARMY TECHNICAL BULLETIN

CALIBRATION PROCEDURE FOR SIGNAL GENERATORS SG-543/U, SG-543B/U, AND SG-543C/U; AND HEWLETT-PACKARD, MODELS 204B AND 204C

Headquarters, Department of the Army, Washington, DC
3 January 2008

Distribution Statement A: Approved for public release; distribution is unlimited.

REPORTING OF ERRORS AND RECOMMENDING IMPROVEMENTS

You can improve this manual. If you find any mistakes or if you know of a way to improve these procedures, please let us know. Mail your letter or DA Form 2028 (Recommended Changes to Publications and Blank Forms) directly to: Commander, U.S. Army Aviation and Missile Command, ATTN: AMSAM-MMC-MA-NP, Redstone Arsenal, AL 35898-5000. A reply will be furnished to you. You may also send in your comments electronically to our E-mail address: 2028@redstone.army.mil or by fax 256-842-6546/DSN 788-6546. For the World Wide Web use: <https://amcom2028.redstone.army.mil>. Instructions for sending an electronic 2028 can be found at the back of this manual.

SECTION		Paragraph	Page
I.	IDENTIFICATION AND DESCRIPTION		
	Test instrument identification	1	2
	Forms, records, and reports	2	2
	Calibration description	3	2
II.	EQUIPMENT REQUIREMENTS		
	Equipment required	4	4
	Accessories required	5	4
III.	CALIBRATION PROCESS FOR SIGNAL GENERATORS SG-543B/U, SG-543C/U, AND HEWLETT- PACKARD, MODEL 204C		
	Preliminary instructions	6	5
	Equipment setup	7	5
	Output voltage.....	8	6
	Frequency accuracy and stability	9	6
	Frequency response.....	10	8

*This bulletin supersedes TB 9 6625-2057-35, 14 March 2005.

	Paragraph	Page
Distortion	11	9
Final procedure	12	10
IV. CALIBRATION PROCESS FOR SIGNAL GENERATOR SG-543/U, AND HEWLETT-PACKARD, MODEL 204B		
Preliminary instructions.....	13	10
Equipment setup	14	10
Frequency accuracy and stability	15	11
Output voltage.....	16	13
Frequency response.....	17	13
Distortion	18	14
Power supply	19	14
Final procedure	20	15

SECTION I IDENTIFICATION AND DESCRIPTION

1. Test Instrument Identification. This bulletin provides instructions for the calibration of Signal Generators, SG-543/U, SG-543B/U, and SG-543C/U, and Hewlett-Packard, Models 204B and 204C. The manufacturers' manuals and TM 11-6625-1589-15-1 were used as the prime data sources in compiling these instructions. The equipment being calibrated will be referred to as the TI (test instrument) throughout this bulletin.

a. Model Variations. Variations among models are described in the text.

b. Time and Technique. The time required for this calibration is approximately 4 hours, using the dc and low frequency technique.

2. Forms, Records, and Reports

a. Forms, records, and reports required for calibration personnel at all levels are prescribed by TB 750-25.

b. Adjustments to be reported are designated (R) at the end of the sentence in which they appear. When adjustments are in tables, the (R) follows the designated adjustment. Report only those adjustments made and designated with (R).

3. Calibration Description. TI parameters and performance specifications which pertain to this calibration are listed in table 1.

Table 1. Calibration Description

Test instrument parameters	Performance specifications
SG-543B/U and SG-543C/U and Hewlett-Packard, Model 204C	
Frequency	Range: 5 Hz to 1.2 MHz Accuracy: $\pm 3\%$ Stability: $\pm 3\%$
Frequency response (into 600 Ω)	
Normal mode	Accuracy: +5 to -1%, 5 Hz to 100 Hz $\pm 0.5\%$, 100 Hz to 300 kHz $\pm 1\%$, 300 kHz to 1.2 MHz
Low distortion mode	Accuracy: +5 to -1%, 5 Hz to 100 Hz $\pm 0.5\%$, 100 Hz to 300 kHz $\pm 1\%$, 300 kHz to 1.2 MHz
Output voltage	Range: 2.5 V ac into 600 Ω
Distortion (into 600 Ω)	Accuracy: As indicated in figure 1 ¹
SG-543/U and Hewlett-Packard, Model 204B	
Frequency	Range: 5 Hz to 560 kHz Accuracy: $\pm 3\%$ Stability: $\pm 3\%$
Frequency response	Accuracy: $\pm 3\%$ into 600 Ω
Distortion	Less than 1% ¹
Output voltage	Range: 2.5 V ac into 600 Ω

¹Not calibrated above 100 kHz.

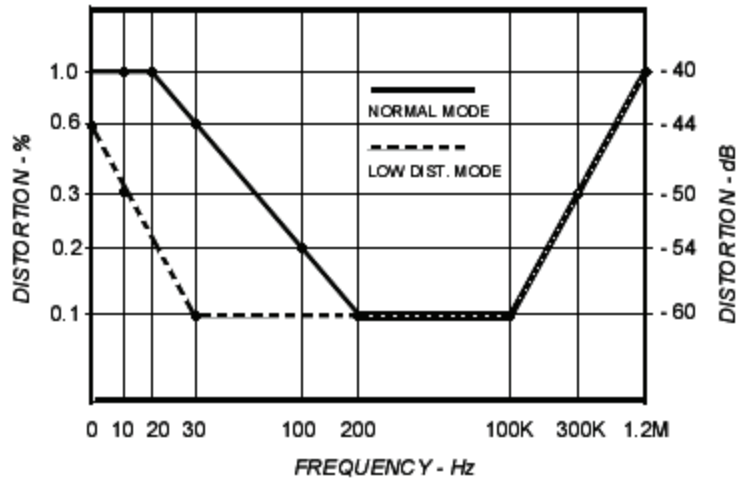

Figure 1. Frequency - Hz.

SECTION II EQUIPMENT REQUIREMENTS

4. Equipment Required. Table 2 identifies the specific equipment to be used in this calibration procedure. This equipment is issued with Secondary Transfer Calibration Standards Set AN/GSM-286, AN/GSM-287 or AN/GSM-705. Alternate items may be used by the calibrating activity. The items selected must be verified to perform satisfactorily prior to use and must bear evidence of current calibration. The equipment must meet or exceed the minimum use specifications listed in table 2. The accuracies listed in table 2 provide a four-to-one ratio between the standard and TI. Where the four-to-one ratio cannot be met the actual accuracy of the equipment selected is shown in parenthesis.

5. Accessories Required. The accessories required for this calibration are common usage accessories, issued as indicated in paragraph 4 above, and are not listed in the calibration procedure. The following peculiar accessory is also required for this calibration: Voltage Divider, 11047A (7911560).

Table 2. Minimum Specifications of Equipment Required

Common name	Minimum use specifications	Manufacturer and model (part number)
AUDIO ANALYZER	Range: 5 Hz to 600 kHz Accuracy: 0.25% Distortion: <-60dB	Boonton, Model 1121 (1121)
AUTOTRANSFORMER	Range: 105 to 125 V ac Accuracy: ±1%	Ridge, Model 9020A (9020A)
CALIBRATOR	Range: 0 to 2.625 V dc Accuracy: ± 0.01%	Fluke, Model 5720A (5700A/EP) (p/o MIS-35947)
FREQUENCY COUNTER	Range: 4.85 Hz to 1.236 MHz Accuracy: ±0.75%	Fluke, Model PM6681/656 (PM6681/656)
MULTIMETER	Range: 0 to 2.5 V ac 0 to 2 V dc Accuracy: ±1%	Fluke, Model 8840A/AF05 (AN/GSM-64D)
THERMAL CONVERTER	Range: 5 Hz to 1.2 MHz at 0.97 to 1.05 V Accuracy: 0.25% 5 to 100 Hz 0.125% (0.5%) 100 Hz to 300 kHz 0.25% (0.6%) 300 kHz to 1.2 MHz	Ballantine, Model 1395-3 (7913198-1)

SECTION III
CALIBRATION PROCESS FOR SIGNAL GENERATORS SG-543B/U, SG-543C/U,
AND HEWLETT-PACKARD, MODEL 204C

6. Preliminary Instructions

a. The instructions outlined in paragraphs 6 and 7 are preparatory to the calibration process. Personnel should become familiar with the entire bulletin before beginning the calibration.

b. Items of equipment used in this procedure are referenced within the test by common name as listed in table 2.

c. Unless otherwise specified, verify the result of each test and, whenever the test requirement is not met, take corrective action before continuing with the calibration. Adjustments required to calibrate the TI are included in this procedure. Additional maintenance information is contained in the manufacturers' manuals and TM 11-6625-1589-15-1 for this TI.

d. Unless otherwise specified, all controls and control settings refer to the TI.

7. Equipment Setup

WARNING

HIGH VOLTAGE is used or exposed during the performance of this calibration. DEATH ON CONTACT may result if personnel fail to observe safety precautions. REDUCE OUTPUT(S) to minimum after each step within the performance check where applicable.

CAUTION

On models with rechargeable batteries do not apply 115 V ac to TI if batteries are removed, otherwise damage will result.

NOTE

Connect a jumper cable between \perp and \downarrow (rear panel) ground connectors.

a. Remove protective cover, as required, only to make adjustments and replace immediately upon completion of adjustment.

b. Adjust **AMPLITUDE** control fully ccw.

c. Set **115/220 V** switch (rear panel) to **115 V**.

d. Connect TI to autotransformer.

e. Connect autotransformer to a 115 V ac source and adjust for 115 V ac output.

f. Set **RANGE** switch to **X5** and allow 20 minutes for equipment to warm-up and stabilize.

8. Output Voltage

a. Performance Check

- (1) Connect **600 Ω** output to multimeter using voltage divider.
- (2) Set **RANGE** switch to **X100** and frequency dial to **10**.
- (3) Adjust **AMPLITUDE** control fully cw.
- (4) Multimeter will indicate at least 2.5 V ac.

b. Adjustments. No adjustments can be made.

9. Frequency Accuracy and Stability

a. Performance Check

- (1) Connect **600 Ω** output to frequency counter using voltage divider.
- (2) Position controls as listed in (a) through (d) below:
 - (a) Frequency dial to **1**.
 - (b) **AMPLITUDE** control full cw.
 - (c) **NORMAL/LOW DIST** switch (rear panel) to **NORM**.
 - (d) Set **RANGE** switch to **X5**.
- (3) If frequency counter does not indicate between 4.85 and 5.15 Hz, perform **b** below.

NOTE

On models that are battery operation only, disregard (4) and (5) below.

(4) Vary autotransformer output between 105 and 125 V ac. Frequency counter indication will remain between 4.85 and 5.15 Hz.

(5) Adjust autotransformer output to 115 V ac.

(6) Set **RANGE** switch and frequency dial for settings listed in table 3. If frequency counter does not indicate within limits specified, perform **b** below.

Table 3. Frequency Dial Accuracy

Test instrument		Frequency counter indications			
RANGE switch settings	Frequency dial settings	Min		Max	
X5	6	29.1	Hz	30.9	Hz
X5	12	58.2	Hz	61.8	Hz
X10	1	9.7	Hz	10.3	Hz
X10	6	58.2	Hz	61.8	Hz
X10	12	116.4	Hz	123.6	Hz
X100	1	97	Hz	103	Hz
X100	6	582	Hz	618	Hz
X100	12	1164	Hz	1236	Hz
X1K	1	970	Hz	1030	Hz
X1K	6	5820	Hz	6180	Hz

Table 3. Frequency Dial Accuracy - Continued

Test instrument		Frequency counter indications			
RANGE switch settings	Frequency dial settings	Min		Max	
X1K	12	11.64	kHz	12.36	kHz
X10K	1	9.7	kHz	10.3	kHz
X10K	6	38.2	kHz	61.8	kHz
X10K	12	116.4	kHz	123.6	kHz
X100K	1	97	kHz	103	kHz
X100K	6	582	kHz	618	kHz
X100K	12	1.164	MHz	1.236	MHz

b. Adjustments

- (1) Set **RANGE** switch to **X1K** and frequency dial to **10**.
- (2) Connect multimeter between TP 4 (fig. 2) and chassis ground.

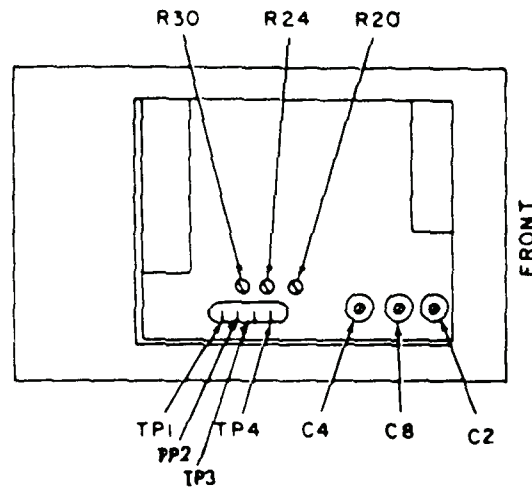

Figure 2. Test instrument left side view.

- (3) Adjust R20 (fig. 2) for 0.0 V dc indication on multimeter (R).
- (4) Adjust frequency dial to 1 and connect positive lead of multimeter to TP 1 (fig 2).
- (5) Adjust R24 (fig. 2) for a -2.0 V dc indication on multimeter (R).
- (6) Set frequency dial to **10** and adjust C2 and C8 (fig. 2) for an indication of 10 kHz on frequency counter and a -2.0 dc indication on multimeter.
- (7) Repeat (4) through (6) above to compensate for interaction.
- (8) Set **RANGE** switch to **X100K** and adjust C4 (fig. 2) for a 1 MHz indication on frequency counter.
- (9) Set **RANGE** switch to **X5** and adjust frequency dial to **1**. Repeat technique of a (2) through (5) above.

10. Frequency Response

a. Performance Check

- (1) Connect equipment as shown in figure 3, CONNECTION A.

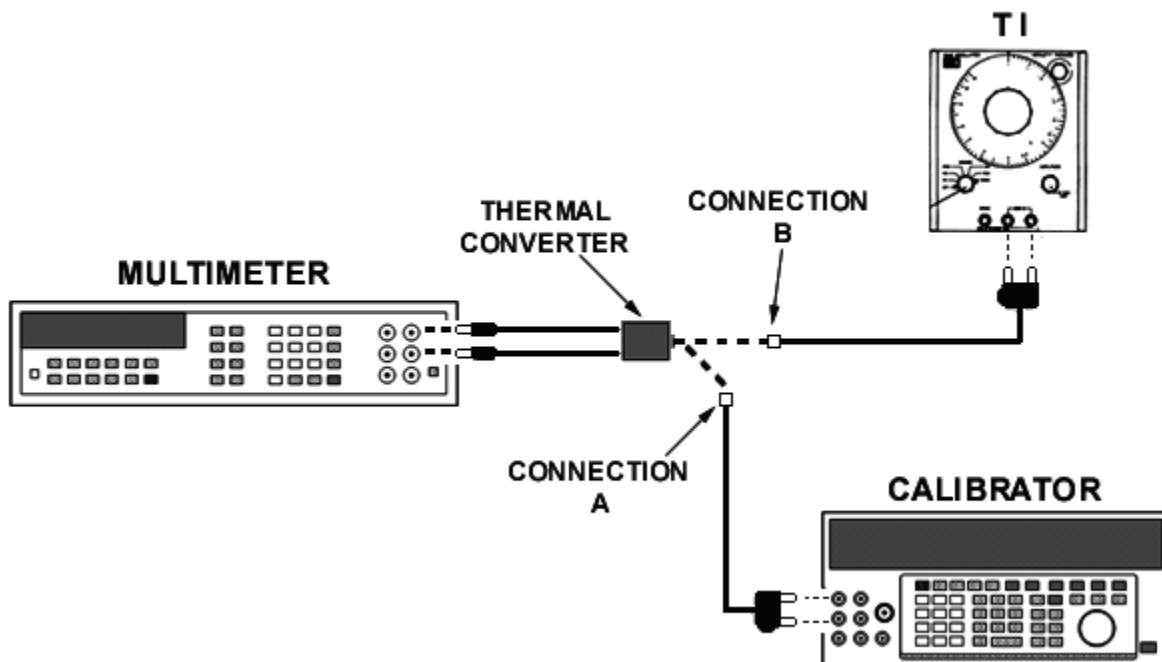

Figure 3. Frequency response - equipment setup.

- (2) Adjust calibrator to 1.0 V dc and record multimeter indication.
- (3) Adjust calibrator to 0.99 V dc and record multimeter indication. Adjust calibrator to 1.05 V dc and record multimeter indication.
- (4) Repeat technique of (3) above for 0.995 and 1.005 V dc respectively.
- (5) Repeat technique of (3) above for 0.99 and 1.01 V dc respectively.
- (6) Connect equipment as shown in figure 3, CONNECTION B.
- (7) Set **RANGE** switch to **X100** and frequency dial to **10**.
- (8) Adjust **AMPLITUDE** control until multimeter indication is the same as recorded in (2) above.
- (9) Set **RANGE** switch and frequency dial as listed in table 4. Multimeter indications will be within appropriate values recorded in (3) through (5) above as listed in table 4.

NOTE

Do not readjust **AMPLITUDE** control.

Table 4. Frequency Response

Test Instrument		Multimeter indications recorded in (3) through (5) above	
RANGE switch settings	frequency dial settings		
X5	1	3	(5) ¹
X10	1	3	(5)
X100	2	4	(4)
X1K	5	4	(4)
X10K	5	4	(4)
X100K	1	4	(4)
X100K	12	5	(5)

¹LOW DIST values are in parenthesis.

(10) Set **NORM/LOW DIST** switch (rear panel) to **LOW DIST**.

(11) Repeat (7) through (9) above.

b. Adjustments. No adjustments can be made.

11. Distortion

a. Performance Check

(1) Connect **600 Ω** output to audio analyzer using voltage divider and set audio analyzer to measure distortion.

(2) Position controls as listed in (a) through (d) below:

- (a) **RANGE** switch to **X100**.
- (b) Frequency dial to **10**.
- (c) **NORM/LOW DIST** switch to **NORM**.
- (d) Adjust amplitude control fully cw.

(3) If audio analyzer does not indicate ≥ 60 dB down (see fig. 1 for dB and % relationship), perform **b** below.

(4) Repeat technique of (2) and (3) above using **RANGE** switch and frequency dial settings listed in table 5. Audio analyzer will indicate within limits specified.

Table 5. Distortion

Test instrument		Audio analyzer indications (dB)	
RANGE switch settings	Frequency dial settings	NORM DIST switch settings	LOW DIST switch settings
X5	2	-40	-50
X10	3	-44	-60
X10	10	-54	-60
X100	1	-54	-60
X1K	1	-60	-60
X1K	10	-60	-60
X10K	1	-60	-60
X10K	10	-60	-60
X100K	1	-60	-60

(5) Set **NORM/LOW DIST** switch to **LOW DIST**.

(6) Repeat technique of (2) and (3) above using **RANGE** switch and frequency dial settings listed in table 5. Audio analyzer will indicate within limits specified.

b. Adjustments

(1) Set **RANGE** switch to **X1K** and frequency dial to **10**.

(2) Adjust R30 (fig. 2) for minimum distortion as indicated on audio analyzer (R).

(3) Repeat a (2) through (6) above.

12. Final Procedure

a. Deenergize and disconnect all equipment.

b. Annotate and affix DA label/form in accordance with TB 750-25.

**SECTION IV
CALIBRATION PROCESS FOR SIGNAL GENERATORS SG-543/U
AND HEWLETT-PACKARD, MODEL 204B**

13. Preliminary Instructions

a. The instructions outlined in paragraphs **13** and **14** are preparatory to the calibration process. Personnel should become familiar with the entire bulletin before beginning the calibration.

b. Items of equipment used in this procedure are referenced within the text by common name as listed in table 2.

c. Unless otherwise specified, verify the result of each test and, whenever the test requirement is not met, take corrective action before continuing with the calibration. Adjustments required to calibrate the TI are included in this procedure. Additional maintenance information is contained in the manufacturers' manuals.

d. Unless otherwise specified, all controls and control settings refer to the TI.

14. Equipment Setup

WARNING

HIGH VOLTAGE is used or exposed during the performance of this calibration. DEATH ON CONTACT may result if personnel fail to observe safety precautions. REDUCE OUTPUT(S) to minimum after each step within the performance check where applicable.

a. Remove TI protective cover as required for adjustment.

CAUTION

On models with rechargeable batteries, do not apply 115 V ac if batteries are removed; otherwise, damage will result.

NOTE

On models that are battery operation only, disregard **b** and **c** below.

- b. Connect TI to autotransformer.
- c. Connect autotransformer, to a 115 V ac source and adjust for 115 V output.
- d. Position controls as listed in (1) through (3) below:
 - (1) **FREQ** dial to 5.
 - (2) **FREQ VERNIER** control to center position.
 - (3) **RANGE** switch to X1.
- e. Wait 20 minutes for equipment to warm-up and stabilize.

15. Frequency Accuracy and Stability**a. Performance Check**

- (1) Connect **OUTPUT 600 Ω** to frequency counter using voltage divider.
- (2) Adjust **AMPLITUDE** control fully cw. If frequency counter does not indicate between 4.85 and 5.15 Hz, perform **b** below.

NOTE

On models that are battery operation only, disregard (3) and (4) below.

- (3) Vary autotransformer output between 105 and 125 V ac. Frequency counter indication will remain between 4.85 and 5.15 Hz.
- (4) Adjust autotransformer output to 115 V ac.
- (5) Set **RANGE** switch and **FREQ** dial for settings listed in table 6. If frequency counter does not indicate within limits specified, perform **b** below.

Table 6. Frequency Dial Accuracy

Test instrument		Frequency counter indications			
RANGE switch settings	Frequency dial settings	Min		Max	
X1	20	19.4	Hz	20.6	Hz
X1	50	48.5	Hz	51.5	Hz
X10	5	48.5	Hz	51.5	Hz
X10	20	194	Hz	206	Hz
X10	50	485	Hz	515	Hz
X100	5	485	Hz	515	Hz
X100	20	1940	Hz	2060	Hz
X100	50	4850	Hz	5150	Hz
X1K	5	4850	Hz	5150	Hz
X1K	20	19.4	kHz	20.6	kHz
X1K	50	48.5	kHz	51.5	kHz
X10K	5	48.5	kHz	51.5	kHz
X10K	20	194.0	kHz	206.0	kHz
X10K	50	485.0	kHz	515.0	kHz
X10K	56 ¹	543.2	kHz	576.8	kHz

¹Not included on all models.

b. Adjustments

- (1) Set **RANGE** switch to **X10K**, **FREQ** dial to **5**, and **VERNIER** control to midrange.
- (2) Adjust C8 (fig. 4) for a 50 kHz indication on frequency counter (R).

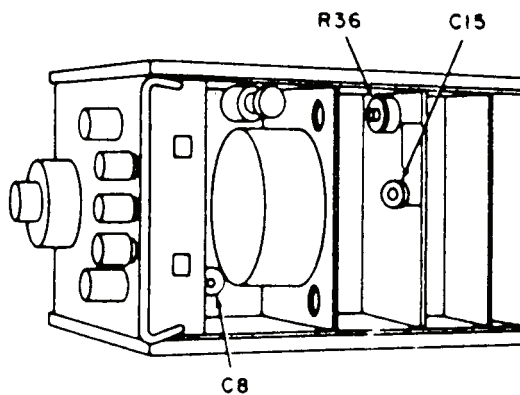

Figure 4. Test instrument bottom view.

- (3) Set **FREQ** dial to **56** and adjust C15 (fig. 4) for a 560 kHz indication on frequency counter.

NOTE

On models that do not include **56** on **FREQ** dial, set **FREQ** dial to **50** and adjust C15 (fig. 4) for a 500 kHz indication on frequency counter (R).

- (4) Set **RANGE** switch to **X1** and **FREQ** dial to **5**.
- (5) Repeat a (2) through (5) above.

16. Output Voltage

a. Performance Check

- (1) Connect **OUTPUT 600 Ω** to multimeter using voltage divider.
- (2) Position controls as listed in (a) through (c) below:
 - (a) **FREQ** dial to **10**.
 - (b) **VERNIER** to mid position.
 - (c) **RANGE** switch to **X100**.
- (3) Adjust **AMPLITUDE** control fully cw. Multimeter will indicate at least 2.5 V ac.

b. Adjustments. No adjustments can be made.

17. Frequency Response

a. Performance Check

- (1) Connect equipment as shown in figure 3, CONNECTION A.
- (2) Adjust calibrator to 1.0 V dc and record multimeter indication.
- (3) Adjust calibrator to 0.97 V dc and record multimeter indication. Adjust calibrator to 1.3 V dc and record multimeter indication.
- (4) Connect equipment as shown in figure 3, CONNECTION B.
- (5) Set **RANGE** switch to **X100** and **FREQ** dial to **10**.
- (6) Adjust **AMPLITUDE** control until multimeter indication is the same as recorded in (2) above.
- (7) Set **RANGE** switch and **FREQ** dial to settings listed in table 7. Multimeter will be within appropriate values as recorded in (3) above.

NOTE

Do not readjust **AMPLITUDE** control.

Table 7. Frequency Response

Test Instrument	
RANGE switch settings	FREQ dial settings
X1	5
X1	50
X10	50
X10	5
X100	5
X1K	5
X1K	50
X10K	5
X10K	56 ¹

¹On models that do not include **56**, set **FREQ** dial to **50**.

b. Adjustments. No adjustments can be made.

18. Distortion

a. Performance Check

- (1) Connect **OUTPUT 600 Ω** to audio analyzer using voltage divider.
- (2) Set **RANGE** switch to **X1** and **FREQ** dial to **5**.
- (3) Adjust **AMPLITUDE** control fully cw. If audio analyzer does not indicate distortion less than one percent (see fig. 1 for dB and % relationship), perform **b** below.
- (4) Repeat technique of (2) and (3) above for **RANGE** switch and **FREQ** dial settings listed in table 8. Audio analyzer will indicate less than one percent on all ranges.

Table 8. Oscillator Distortion Check

Test Instrument	
RANGE switch settings	FREQ dial settings
X10	5
X10	10
X100	1
X1K	10
X10K	10

b. Adjustments

- (1) Set **RANGE** switch to **X100** and **FREQ** dial to **10**.
- (2) Adjust R36 (fig. 4) for minimum distortion as indicated in audio analyzer (R).

19. Power Supply

NOTE

Do not perform power supply check if all other parameters are within tolerance.

a. Performance Check

- (1) Connect **OUTPUT 600 Ω** to multimeter.

NOTE

For models that rechargeable batteries, connect multimeter between junction of TI and C102 (fig. 5) and floating ground (located on front panel binding post.)

- (2) Position controls as listed in (a) through (c) below:
 - (a) **FREQ** dial to **10**.
 - (b) **RANGE** switch to **X100**.
 - (c) **AMPLITUDE** control fully cw.
- (3) Adjust **DC BAL** (rear panel) for a 0.0 V dc indication on multimeter.

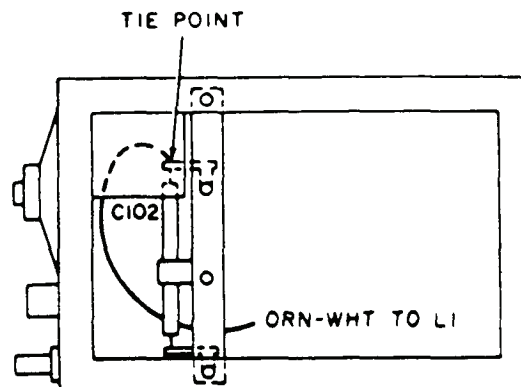

Figure 5. Test point location.

NOTE

If TI contains battery pack power supply and tolerance is not met, it may be necessary to recharge or replace battery pack. If batteries are rechargeable, allow 20 minutes for recharge.

b. Adjustments. No further adjustments can be made.

20. Final Procedure

- a. Deenergize and disconnect all equipment.
- b. Annotate and affix DA label/form in accordance with TB 750-25.

By Order of the Secretary of the Army:

Official:



JOYCE E. MORROW
*Administrative Assistant to the
Secretary of the Army*

0730502

GEORGE W. CASEY, JR.
*General, United States Army
Chief of Staff*

Distribution:

To be distributed in accordance with the initial distribution number (IDN) 342206, requirements for calibration procedure TB 9-6625-2057-24.

Instructions for Submitting an Electronic 2028

The following format must be used if submitting an electronic 2028. The subject line must be exactly the same and all fields must be included; however, only the following fields are mandatory: 1, 3, 4, 5, 6, 7, 8, 9, 10, 13, 15, 16, 17, and 27.

From: "Whomever" whomever@redstone.army.mil

To: <2028@redstone.army.mil

Subject: DA Form 2028

1. **From:** Joe Smith
2. **Unit:** home
3. **Address:** 4300 Park
4. **City:** Hometown
5. **St:** MO
6. **Zip:** 77777
7. **Date Sent:** 19-OCT-93
8. **Pub no:** 55-2840-229-23
9. **Pub Title:** TM
10. **Publication Date:** 04-JUL-85
11. **Change Number:** 7
12. **Submitter Rank:** MSG
13. **Submitter FName:** Joe
14. **Submitter MName:** T
15. **Submitter LName:** Smith
16. **Submitter Phone:** 123-123-1234
17. **Problem:** 1
18. **Page:** 2
19. **Paragraph:** 3
20. **Line:** 4
21. **NSN:** 5
22. **Reference:** 6
23. **Figure:** 7
24. **Table:** 8
25. **Item:** 9
26. **Total:** 123
27. **Text**

This is the text for the problem below line 27.

